

Use only 2000 Plus® HD Series ink when re-inking your stamp.  
Using alternative inks can potentially clog or damage your stamp.

## Re-inking your stamp

---

1. While holding only the base of the stamp with one hand, use your free hand to pull off the stamp handle by simultaneously pulling up on both sides of the handle (do not pull up on the index lens, pull up on the black plastic sides where the two ridges reside).
2. Open the dust cover from the bottom of the stamp, or remove completely if not attached to base.
3. Hold the base of the stamp a few inches above a piece of scrap paper. Carefully push down on the exposed plunger to release the ink cartridge assembly from the stamp housing.
4. Place 10 drops of ink in each hole on the back of the ink cartridge. **Do not ink directly on the front of the text plate.**

turn for reassembly instructions

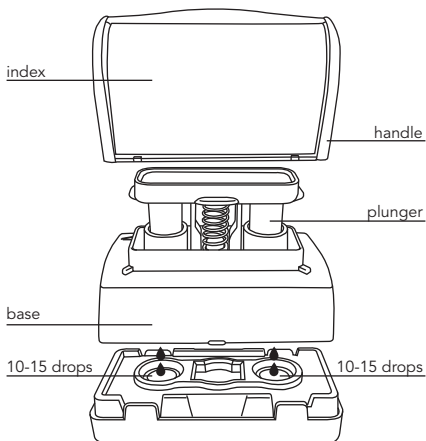

Use only 2000 Plus<sup>®</sup> HD Series ink when re-inking your stamp.  
Using alternative inks can potentially clog or damage your stamp.

## Re-assembling your stamp

---

1. Align stamp base over the ink cartridge and press down on the plunger to reassemble the cartridge and base. Be sure the cartridge is facing in the correct direction or your stamp may be re-installed upside down.
2. Place the handle back over the plunger and snap back into place by firmly pressing down on the handle.
3. Allow 15-30 minutes for the fresh ink to migrate thru the ink cartridge and text plate.